

Installation Instructions and User Guide

Platinum 1200T

Garage Door Driver I

600N

800N

1000N

1200N

1500N

WARNING

Please read the manual carefully before installation and use. The installation of your new door opener must be carried out by a technically qualified or licensed person. Attempting to install or repair the door opener without suitable technical qualification may result in severe personal injury, death and / or property damage.

CONTENTS

Important safety recommendations.....	1-2
Basic function introduction.....	3
Special function introduction.....	3
Installation.....	4
Installation (aluminum track)	5-6
Installation (one-piece steel track).....	7-8
Installation (sectional steel track).....	9
Installation recommendations.....	10
Basic function setting.....	11-12
Special function introduction (optional).....	13
Wiring guide.....	14
Manual disengagement.....	15
Maintenance.....	15
Manufacturer's declaration.....	16
Final note.....	16
Technical specifications.....	16
Standard packing list.....	17
General Error Code.....	17

Important safety recommendations

The new GDO is professional designed under the newest design idea. The installation and setting of this GDO is extremely easy. It has complete functions, give the users a relaxed and happy installation experience.

Safety Warnings

Warning: It is very important to read this safety warnings and follow all instructions before installing. Or it may cause serious personal injury and/or property loss. Save these instructions

1. This appliance can be used by children aged from 8 years and above and persons with reduced physical, sensory or mental capabilities or lack of experience and knowledge if they have been given supervision or instruction concerning use of the appliance in a safe way and understand the hazards involved. Children shall not play with the appliance or its controls, including transmitters. Keep the transmitters out of the reach of children. Cleaning and user maintenance shall not be made by children without supervision.
2. We strongly recommend to install photocell to increase safety protection and psychological security.
3. Before installing the drive, remove all unnecessary ropes or chains and disable any equipment, such as locks, not needed for powered operation. Check that the door is in good mechanical condition, correctly balanced and opens and closes properly.
4. A-weighted emission sound pressure level of the drive $LpA \leq 70$ dB(A).
5. The operator must not be used for doors without a safety catch.
6. Install the actuating member for the manual release at a height less than 1,8 m. If removable, the actuating member should be stored in direct vicinity of the door.
7. Install any fixed control at a height of at least 1,5 m and within sight of the door but away from moving parts.
8. Wall switch or wall transmitter must be installed out of the reach of children.
9. Permanently fix the labels warning against entrapment in a prominent place or near any fixed controls.
10. Permanently fix the label concerning the manual release adjacent to its actuating member.
11. After installation, ensure that the mechanism is properly adjusted and that the drive reverses or the object can be freed when the door contacts a 50 mm high object placed on the floor. Ensure that parts of the door do not extend over public footpaths or roads.
12. Refer to pages 4-8 for information on how to adjust the door and drive.
13. Connect the GDO to 230-240V circuit, and fix it to the required place by professional person.

WARNING: The drive shall be disconnected from its power source during cleaning, maintenance and when replacing parts.



- 14. Waste electrical products should not be disposed of with household waste. Please recycle where facilities exist. Check with your local authority or retailer for recycling advice.**
15. If the supply cord is damaged, it must be replaced by the manufacturer, its service agent or similarly qualified persons in order to avoid a hazard.
16. Watch the moving door and keep people away until the door is completely opened or closed.
17. Take care when operating the manual release since an open door may fall rapidly due to weak or broken springs, or being out of balance.
18. Check the condition of the door frequently if has any damage or if is well balanced., especially the cable, spring, components connect with the wall. Don't use the door if it is not repaired or adjusted, or there will be injury due to improper installation or bad balance. If the door components are under extreme pressure, don't repair it by yourself, if necessary, call for authorized service.
19. Each month check that the drive reverses or the object can be freed when the door contacts a 50 mm high object placed on the floor.
20. The drive must not be used with a door incorporating a wicket door (unless the drive can not be operated with the wicket door not put in the safe position).
If applicable, that the drive is not to be used with doors having openings exceeding 50 mm in diameter or having edges or protruding parts a person could grip or stand on.
21. Don't open/close the door when people are near the door. Keep children away from the moving door. Or it may cause serious personal injury and/or property loss.
22. In order to keep the GDO away from the rain, don't expose it out door. Don't put the GDO in the water, don't spray water to the GDO, keep the GDO away from any other device with water.
23. In order to make sure the GDO can sense the obstacle under the door, the door must press the obstacle. So it may cause injury or damage to the obstacle, door or person.
24. If the circuit is damaged, the professional person is required to do the repair.
25. Make sure the garage door is fully open & stationary before passing through the door. Make sure the garage door is fully closed & stationary before leaving.

The device is intended for the opening and closing of tilt-up and sectional garage doors in the private sector.

For 600N, it is the best for the door less than 10m², 100kgs.

For 800N, it is the best for the door less than 12m², 120kgs.

For 1000N, it is the best for the door less than 14m², 140kgs.

For 1200N, it is the best for the door less than 16m², 160kgs.

For 1500N, it is the best for the door less than 18m², 180kgs.

The device is not meant for commercial use but solely for the use in private garage doors that are appropriate for a single household. The device is installed indoor and max 2,5m away the door, and min 0,5m away the ceiling of garage. Check the Installation instruction for details. Any improper use of the drive could increase the risk of accidents.

Basic function introduction

1. Soft start, soft stop. Minimize start-up load on garage door opener and garage door
2. The door will stop during opening when contacting obstruction, and will reverse at least 30cm during closing when contacting obstruction.
3. Opening & closing force dynamically self-learning. Can make sure the garage door driver will work steadily in spite of change of door resistance by seasonal variation.
4. Safety resistance adjustable, with a wide range, sensitive and reliable.
5. Overloading force detecting, the door will reverse more than 15 cm automatically when it is overloaded when closing and will stop when it is overloaded when opening.
6. Low-voltage protection, the process will not perform any action of opening and closing when voltage is too low, door panel and controller won't be damaged.
7. We adopt rolling code transmitter, with billions of codes, won't be coincident code or pirated code.
8. Auto-close function available.
9. Backup battery interface available, in case of power failure.
10. Wall switch interface available.
11. Photocell interface available, the door will change to open when obstruction is detected while closing.

Special function introduction (optional)

The following functions are made to order in accordance with the special needs of customers:

1. Flash light feature
2. Pass door protection feature
3. Remote lock function
4. Half-opening function

Installation

- 1). Read the instructions carefully.
- 2). Make sure the door structure is solid and suitable to be motor driven.
- 3). Make sure that when the door is moving there are no friction points.
- 4). The door must be properly balanced and must be easily lowered and raised by hand.
- 5). Install a 230-240V, adequately protected 3-pin socket near where the GDO is going to be installed.

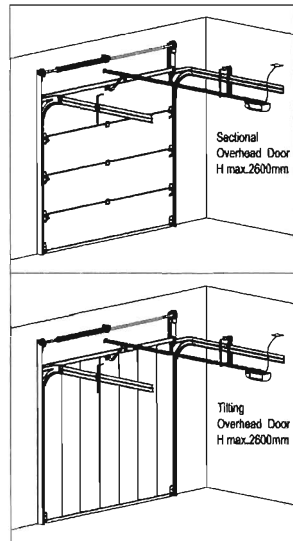

Fig.1

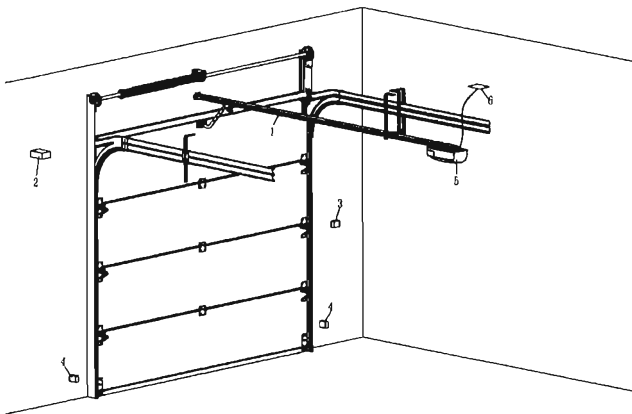

Fig.2

Referring to Fig. 2 for recommended installation

- | | |
|---|-----------------|
| 1) Opener track | 5) Opener |
| 2) 24V DC flashing light (optional extra) | 6) Power socket |
| 3) Push button | |
| 4) Photo beam (RX/TX Type) | |

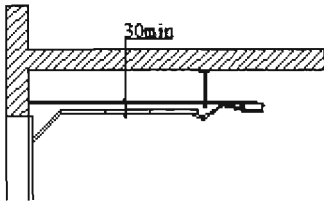

Fig.3

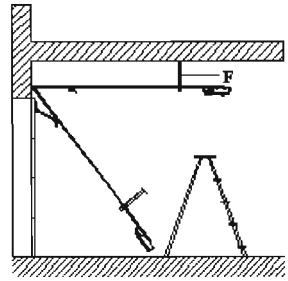

Fig.4

Maintain a minimum gap of 30mm from the top panel's maximum height (Fig. 3).

Make sure the track is horizontal and vertical to the shaft. Make sure the connection of hanging bracket F and ceiling is firm enough (Fig. 4).

Warning: Make sure the opener is affixed to noggins in ceiling and not to plasterboard. Failure to have a safe and secure fixing will lead to opener falling, and cause serious persons and /or property damage.

Installation (aluminum track)

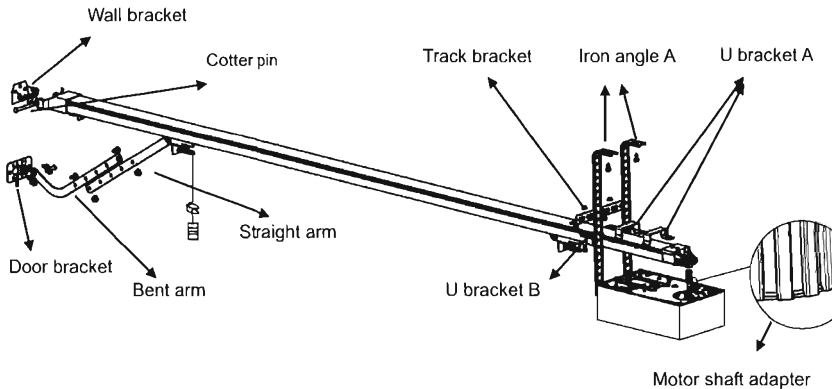

Fig.5

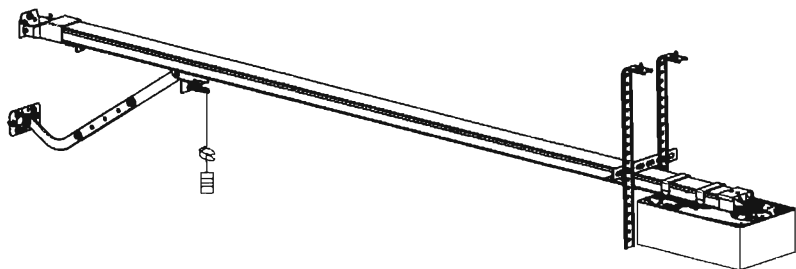

Fig.6

Installation procedure

1. Fixing the wall bracket. Fixing the wall bracket to the wall 2cm-15cm over the shaft or intermediate bracket (depend on the actual installation space).
2. Fixing the steel track to the wall bracket with cotter pin.
3. Sleeve the motor shaft adapter to the motor shaft according to Fig. 5.

Notice: the flanged end facing down.

4. Fixing garage door opener to the track by U bracket A . It's enough for 2 Nm fastening force.
5. Fixing the track bracket with U bracket B. Fix the track bracket as closer to the opener as you can, if there is enough space.

Notice: Make sure the track is horizontal and vertical to the shaft.

6. Fixing the iron angle A to track bracket, hanging the track to ceiling by iron angle A. Make sure the connection of iron angle A and ceiling is firm enough.
7. Fixing the door bracket on the door panel, fixing the straight arm and bent arm, fixing the clutch cord.
8. Release the clutch, try to open and close the door by hand. Make sure there is no resistance between door panel and track.
9. Connecting the opener with power and adjusting the operation.

Notice: Make sure the opener's voltage is in accordance with the local voltage. Connect the opener to a properly earthed power supply.

Installation (one-piece steel track)

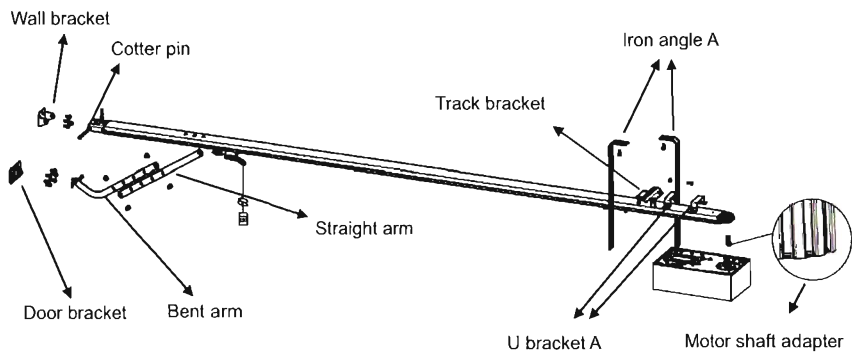

Fig. 7

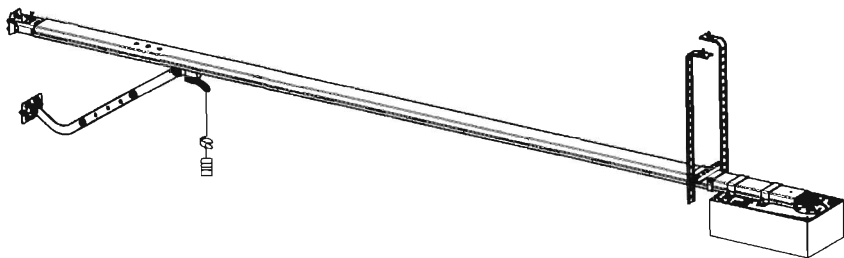

Fig. 8

Installation procedure

1. Fixing the wall bracket. Fixing the wall bracket to the wall 2cm-15cm over the shaft or intermediate bracket (depend on the actual installation space).

2. Fixing the steel track to the wall bracket with cotter pin.

If the track is with belt, then go for step 3, if track is with chain, then skip to step 4

3. Sleeve the motor shaft adapter to the motor shaft according to Fig. 6

Notice: the flanged end facing down.

4. Fixing garage door opener to the track by U bracket A . It's enough for 2 Nm fastening force.

5. Fixing the track bracket to the track. Fix the track bracket as closer to the opener as you can, if there is enough space.

Notice: Make sure the track is horizontal and vertical to the shaft.

6. Fixing the iron angle A to track bracket, hanging the track to ceiling by iron angle A. Make sure the connection of iron angle A and ceiling is firm enough.

7. Fixing the door bracket on the door panel, fixing the straight arm and bent arm, fixing the clutch cord.

8. Release the clutch, try to open and close the door by hand. Make sure there is no resistance between door panel and track.

9. Connecting the opener with power and adjusting the operation.

Notice: Make sure the opener's voltage is in accordance with the local voltage. Connect the opener to a properly earthed power supply.

Installation (sectional steel track)

1. Cut the plastic cable tie on the first piece track



2. Fix the first sleeve to the first piece track

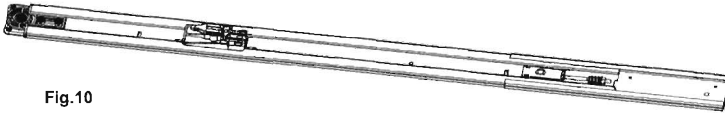

3. Fix the second piece track to another end of first sleeve



4. Repeat above steps to fix the second sleeve, third piece track

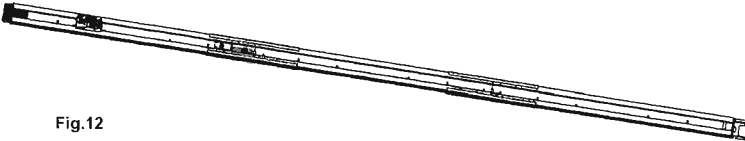

5. Pull the rod along the track towards another end

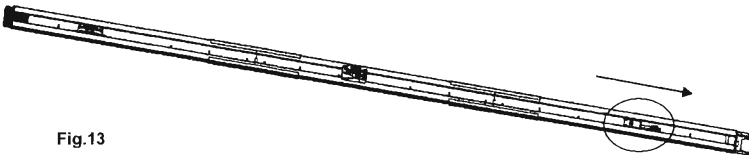

6. Fix rod according to below picture

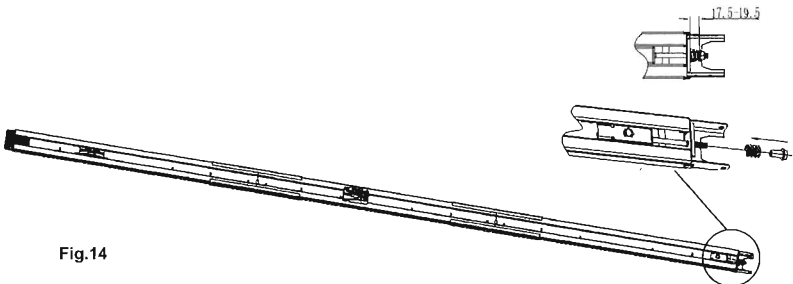

7. Install according Fig. 7

Installation recommendations

Remember there are specific standards that have to be strictly followed regarding the safety rules of electrical installations and automatic gates and doors.

As for the legal requirements and standards that must be adhered to, please take notice of the following points to ensure maximum safety and reliability of your installation.

1. Before installing checking the surrounding environment. Carefully evaluate any hazards which could be physical damage (transiting vehicles, parts of trees falling etc.), possible contact with persons' bodies (insects, leaves, etc.), flooding hazards, or any others exceptional events.
2. Check the main voltage numbers is the same as the numbers that are given on the rating plate and in this manual.
3. Check and make sure if there is suitable electrical protection against short circuits/power spikes and proper earthing on the main supply.

Remember the unit having main voltage running through it (electrocution hazard, fire hazard).

4. Take care with the control unit; the parts may be subject to damage if the control unit is abused.
 5. Make sure that you have all the necessary materials, and they are suitable for this kind of use.
 6. Read all the instructions thoroughly, and make sure they are understood before attempting to install the opener.
 7. Before starting the installation carefully analyze all the risks relating to automating the door. Verify that the door is automated in a sound condition and that the mechanisms are in good working order. Observe the safety margins and minimum distances.
 8. Carefully evaluate the safety devices to be installed and the right place to install them; always install an emergency stop device for power interruption to the opener if it is required.
 9. Once the risks have been analyzed, install the opener and relative safety devices, emergency stop and/or photoelectric cells.
- Important note:** As for additional safety rules, we strongly recommends the fitting of Photo Electric safety beams on all installations.
10. While installing the opener, strictly follow all the instructions given in the instruction manual. If some points or procedures in this manual are not very clear do not install the unit until all doubts have been cleared up with our technical department.

Basic function setting

1. Limit setting Opening & closing force dynamically self-learning

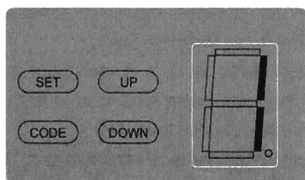

Press 'SET' button and hold on until the LED displays figure '1', then adjust the up limit by pressing 'up' button. Fine-tuning 'UP' or 'DOWN' button to determine the final up limit position then press 'SET' button the display turn into '2' automatically. Adjust the down limit by pressing 'down' button. Fine-tuning 'UP' or 'down' button to determine the final down limit position then press 'SET' button. The opener will operate a cycle automatically to remember the limit positions and the opening & closing force.

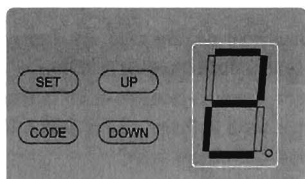

2. Matching the receiver and transmitter

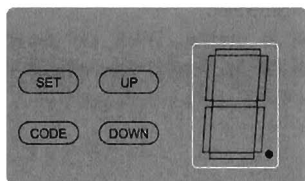

Press 'CODE' button and hold on until the LED dot flashes. (Fig.A) Then press any button on the transmitter, the dot will be off; press the button again the dot will fast flash then LED displays 'u' (Fig.B). After that the transmitter will be available. It will be able to control the open, close, stop of the garage door driver.

Fig. A

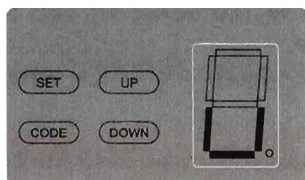

Press 'CODE' button more than 8 seconds (the LED dot flashes) until the LED displays 'C', all the stored codes will be deleted.

Fig. B

3. Safety reverse force adjustment

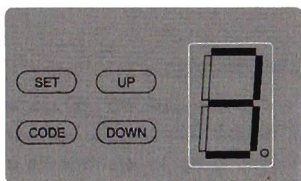

Press 'SET' button and hold on until the LED displays '3'. It's under force adjustment mode. LED shows the current force level.

Press 'UP' button to increase the force level and 'DOWN' button to decrease the force level.

Version 1: Maximum force level is 9, minimum is 1. Please make sure the photo beam is connected and can work properly before you choose level 4~9.

Version 2: Maximum force level is 3, minimum is 1. Press 'SET' button to confirm.

4. Auto-close setting

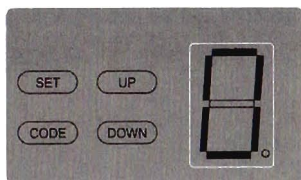

Press 'UP' button and hold on, the LED will display the current setting (the factory default setting is '0').

Press 'up' button once, the auto-close time will increase 1 level, the maximum is level 9. Press 'down' button once, the auto-close time will decrease 1 level.

The auto-close function will be turned off when LED displays 0.

Version 1: 1 level = 60seconds

Version 2: 1 level = 15seconds

Press 'SET' button to confirm. When the auto-close function is activated, the full opened door will auto-close after the set time.

5. Photo beam setting

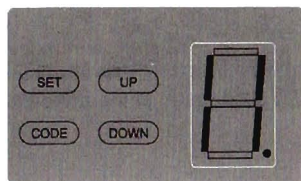

Press 'DOWN' button and hold on until the LED displays 'H'.

Press 'UP' button the LED displays 'H', photo beam function is available.

Press 'DOWN' button the LED displays 'H' to cancel this function.

Press 'SET' to confirm.

Make sure that the connected infrared sensor is controlled by switching value, and wiring as Fig. 15

Notice: If photo beam function is activated, while the photo beam is not connected, the door will not close.

6. O/S/C Terminal

Connecting a touch off switch to this terminal (Fig. 16), you can use the switch inside the garage to control the open/stop/close of the door when maintaining or the transmitter is lost.

Special function introduction (optional)

The following functions are made to order in accordance with the special needs of customers:

1. Flash light function

There are corresponding interfaces for this function and provide 24v-35v flash light voltage. Connect the flash light with DC 24v-28v, current $\leq 500\text{mA}$ (Fig.18). When use AC 230-240V power flash lights, please match an adapter, and wiring as required (Fig.19).

2. Pass door (SD) protection

This function ensures that the door can't be opened unless the small pass door is closed. The door panel won't be damaged. Connect according to Fig.17.

3. Remote lock function

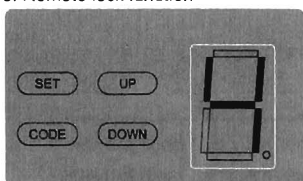

Press and hold on 'SET' button until the LED displays '4'. It's in remote lock function setting mode.

Press 'UP' button, the LED displays '1', the transmitter lock function is available. Press 'DOWN' button the LED displays '0', the lock function has been turned off.

Press 'SET' to confirm.

You have to press lock button on remote a few seconds later after the door was fully closed, then you can open the door again by remote.

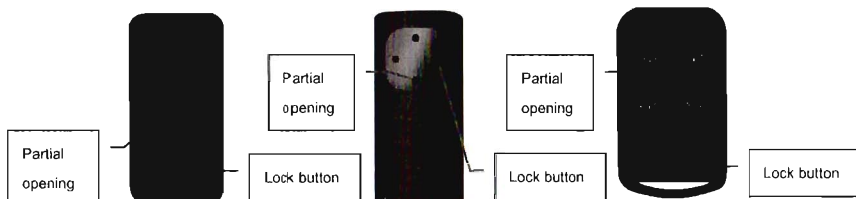

4. Partial opening function

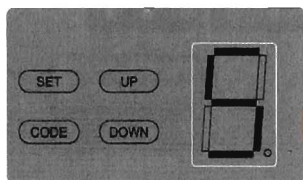

Press and hold on 'SET' button until the LED displays figure '5'. It's in partial opening function setting mode.

Press 'UP' or 'DOWN' button, the LED will display figure '0' to '9' automatically.

When LED displays '0', the partial opening function is invalid;

When displays '1', the door will stop at 30cm above ground;
When displays '2', the door will stop at 60cm above ground, and so forth.

When LED displays '9', the door will stop at 270cm above ground.

The function defaults to invalid when the stated range is over than the door's limited opening range.

Press 'SET' button again to confirm.

Wiring guide

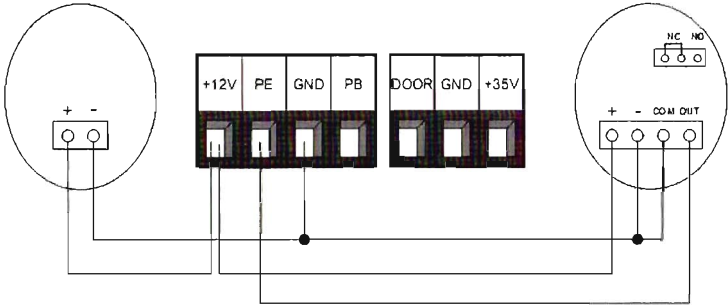

NO/NC photo beam

Fig.15

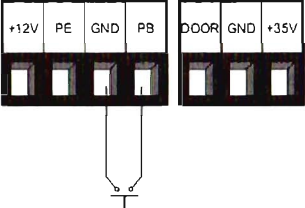

Push Button

Fig. 16

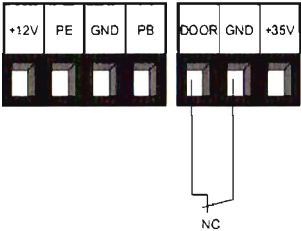

Pass-door safety device

Fig. 17

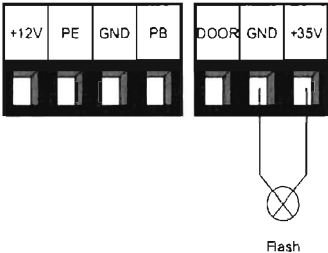

DC Flash Light

Fig. 18

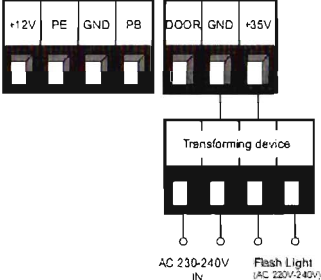

AC 230-240V Flash light

Fig. 19

Manual disengagement

The opener is equipped with a manual release cord to disengage shuttle and move door by hand while holding the handle down (Fig 19). Pull on the handle to disengage the shuttle. To re-engage the door simply run opener in automatic mode or move door by hand until the trolley engages in the chain shuttle.

In some situations that a pedestrian door is not in state, it is recommended that an external disengagement device should be fitted (Fig 20).

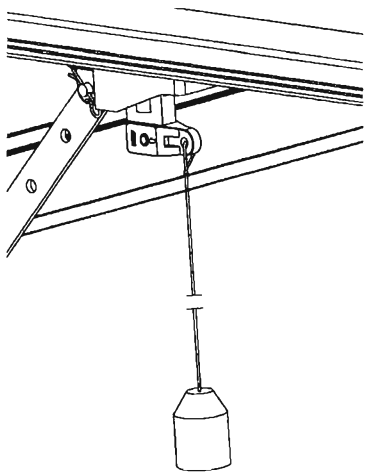

Fig. 19

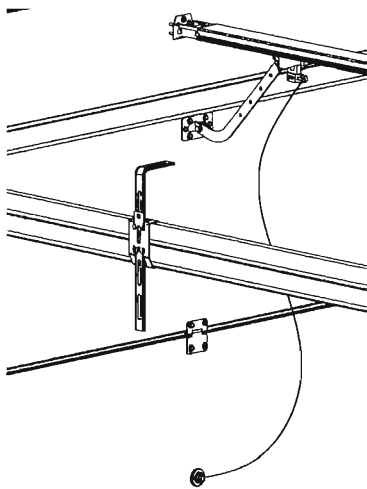

Fig. 20

Maintenance

No particular maintenance is required for the logic circuit board.

Check the door at least twice a year if it is properly balanced, and all working parts are in good working condition or not.

Check the reversing sensitivity at least twice a year, and adjust if it is necessary.

Make sure that the safety devices are working effectively (photo beams, etc.)

Notice: A rude operating door can affect the life of the automatic opener due to incorrect loads, and will void the warranty.

Manufacturer's Declaration

We hereby declare that the product of this model corresponds in its design, construction and version to the relevant and basic health and safety requirements of the following EC regulations: EMC Directive and Low Voltage Directive. The detailed standards are as follows:

EN 55014-1, EN 55014-2, EN 61000-3-2, EN 61000-3-3

EN 301 489-1, EN 301 489-3

EN 60335-1, EN 60335-2-95, EN 62233

Final notes

This manual is only used by technical persons who are qualified to carry out the installation.

No given information in this manual can be considered of any interest to the end user.

It is important for the installer to show their clients correct operation using of the opener including the using of manual disengagement cord.

Inform the owner about the need of a regular and accurate maintenance, especially regarding a regular check of the safety and reversing devices.

Technical specifications

Model	600N	800N	1000N	1200N	1500M
Power Input	200W	235W	245W	260W	300W
Max force	600N	800N	1000N	1200N	1500N
Door opening size	10m2, 100kgs	12m2, 120kgs	14m2, 140kgs	16m2, 160kgs	18m2 180kgs
Input Voltage	230-240VAC 50/60Hz (subject to customer's area)				
Light time	3 minutes				
Working temperature	-20° ~ 40°C				
Relative Humidity	<90%				
Radio frequency	433.92MHz or other on request				
Decoding	Rolling code				
Transmitter power	12V Battery				
Lamp	Chip LED				

Standard packing list

Item	Quantity
Door opener	1
Track (incl. Clutch)	1
Remote control	2
Door bracket	1
Wall bracket	1
"U" bracket A	2
"U" bracket B (If aluminum track)	1
Iron angle A	2
Track bracket	1
Clutch cord	1
Cord pendant	1
Straight arm	1
Bent arm	1
Fixing kit	1

General Error Code

Code	Failure	Possible causes	Proposed solutions
E1	No signal detected on main hall sensor	Main hall sensor loose	Check & fix connection between main hall sensor and PCBA.
E2	No signal detected on sub hall sensor	Sub hall sensor loose	-Check & fix connection between sub hall sensor and PCBA. -Power off and restart the device
E3	Sub hall count faster than main hall	Main hall sensor and sub hall sensor wire switched	Swap main hall sensor and sub hall sensor wire on PCBA, learn travel limit again.
E4	Wicket door terminal open circuit	-Wicket door is open -Wicket door connecting wire is loose	-Close the wicket door -Fasten the wicket door connecting wire
E5	Motor not work	-Incorrect type motor is used -Motor is damaged	-Replace with a correct type motor -Replace with a new motor
E6	Door blocked during closing	-There's object under the door -Stuck between door	-Move away object under the door -Adjust door installation & reset travel limit

