

Sliding Gate Opener

Installation Manual and Owner's Guide

VICWAY V-500



PLEASE READ THE MANUAL CAREFULLY BEFORE INSTALLATION AND OPERATION

This manual contains important information regarding personal safety. Please read and understand this manual before installation and use. We disclaim all responsibility for any damage resulting from improper use of our gate opener.

Contents

1、 Inventory	3
2、 Feature Introduction	4
3、 Installation	5
4、 Programming	11
5、 Technical Data	15
6、 Maintenance	16
7、 Trouble Shooting	17

7、 Trouble Shooting









Fault	Causes	Solutions
The gate does not move when pressing the transmitter.	<ol style="list-style-type: none"> 1. The plug is not securely connected. 2. The clutch is disengaged. 3. Photocell malfunction. 4. The fuse is blown. 5. The memory of the transmitter code has been deleted. 	<ol style="list-style-type: none"> 1. Have the power supply connected securely by a qualified technician. 2. Engage the clutch with the release key, see 3-8 on Page 10. 3. Check the photocell, if the photocell is damaged, replace with a new pair. If no photocells installed, connect the terminal IRGND and IR on P4 with a short cable. 4. Replace with a new fuse. 5. Memorize the transmitter see 4-10 on Page 14.
When opening or closing the gate, the movement would not stop.	<ol style="list-style-type: none"> 1. The gear racks have been installed with the teeth on the upside. 2. The terminals SW1 and SW2 on P4 are connected reversely. 	Exchange the connection of the terminals SW1 and SW2.
The gate does not reverse when meeting obstacles.	<ol style="list-style-type: none"> 1. The gate closing direction has been set reversely. 2. The force is set at too high level. 	<ol style="list-style-type: none"> 1. Push Switch 5 on SW1 to the other position, see 4-6 on Page 13 . 2. Turn the force setting button anti-clockwise to adjust the force to a proper level, see 4-8 on Page 13.
The gate opens automatically during the closing procedure.	The force has been set at a too low level.	Turn the force setting button clockwise to adjust the force to a proper level, see 4-8 on Page 13.
The gate opens automatically when the door is completely closed.	<ol style="list-style-type: none"> 1. The limit switch bracket is not correctly installed and can not hit the switch spring to stop the gate that it allows the gate to hit the mechanical stop and reverse. 2. The gate closing direction has been set reversely and the automatic closing gate function has been set on. 	<ol style="list-style-type: none"> 1. Adjust the limit switch bracket to a proper position and make sure it hits the switch spring when the door moves to the closed limit position. 2. Push Switch 5 on SW1 to the other position, see 4-6 on Page 13 .
The motor does not run when pressing the transmitter.	<ol style="list-style-type: none"> 1. The battery of the transmitter has not enough power. 2. The transmitter has not been programmed to the motor yet. 	<ol style="list-style-type: none"> 1. Replace the battery of the transmitter with a new one of the same type. 2. Memorize the transmitter see 4-10 on Page 14.
The gate can not open completely.	The user control the gate by predestrian access button in error.	Control the gate by pressing full opening/closing button, full opening/closing button coding please see 4-10 on Page 14.
The gate can not close completely.	The force setting is too weak.	Turn the force setting button clockwise to a proper level see 4-8 on Page 13.

IMPORTANT SAFETY INSTRUCTIONS

WARNING: It is important for the safety of persons to follow these instructions. Save these instructions.

- Never immerse components in water or other liquid. Also do not allow liquids to enter the motor or other open devices during installation.
- Immediately disconnect the power supply if liquid substances have penetrated into the automation devices.
- Do not allow children to play with fixed controls. Keep remote controls away from children.
- Please mind the moving gate and keep people away until the gate is completely open or closed.
- Frequently examine the installation for imbalance and signs of wear or damage to cables and mounting. Do not use if repair or adjustment is necessary.
- Maintenance operations and repairs can be only performed by qualified technicians.
- Disconnect the power supply when cleaning or other maintenance is being carried out.
- Make sure the grounding is well connected before connecting the power supply.
- For further safety, photocells and flashing light are recommended to be installed together with the gate opener.
- Power switch should be installed separately in order to power off in case of emergency.

1. Inventory

Picture	Name	Quantity
	Motor	1
	Instruction manual	1
	Transmitter	2
	Base plate	1
	Screw(8×40), washer, nut	4
	Limit switch bracket	2
	Release key	1
	Photocell (optional)	1
	Flashing light (optional)	1

6. Maintenance

The F-500 motor normally requires no particular maintenance. The only maintenance operations that the user can and must perform regularly is the cleaning of the photocell glasses and testing of the photocell efficiency.

Cleaning: Use a slightly damp cloth(not wet) to clean the surface of the devices. Do not use any substances containing alcohol, benzene, diluents or other flammable substances. The use of these substances could damage the devices or cause electric shocks.

Testing: During the closing movement of the gate, pass a cylinder of 5cm diameter and 30cm long on photocell beam, first near the emitter, then near the receiver, finally at the middle point of the beam. Make sure the closing movement of the gate stops and reverses in all these cases.

This testing should be carried out regularly at least every 6 months.

5、 Technical Data

Item No	F-500A	F-500B	F-500M	F-500G	F-500M
Max. gate weight	400KG	800KG	1200KG	1600KG	1200KG
Max. gate length	5m	7m	9m	11m	9m
Input power	200W	250W	330W	350W	330W
Working voltage	220V-240V	220V-240V	220V-240V	220V-240V	110~120V
Thermal protection temperature	120°C	120°C	120°C	120°C	120°C
Motor rotate speed	1400rpm	1400rpm	1400rpm	1400rpm	1400rpm
Max. frequency of cycles	100 complete cycles per day, max. 20 cycles per an hour.				
Gate moving speed	11.58m/min	11.58m/min	11.58m/min	11.58m/min	11.58m/min
Working temperature	-20°C-40°C	-20°C-40°C	-20°C-40°C	-20°C-40°C	-20°C-40°C
Protection class	IP24	IP24	IP24	IP24	IP24

2、 Features Introduction

- Timely resistance detection, automatic reverse when obstacles are met.
- Transmitter with rolling code technology provides protection against unauthorized access.
- Powerful AC motor with low noise & overheat protection.
- Emergency release provides manual operation in case of power failure.
- Safety further ensured with optional accessories like photocells & flashing lights.

3、 Installation

IMPORTANT SAFETY INSTRUCTIONS FOR INSTALLATION

WARNING: Follow all instructions since incorrect installation can lead to severe injury.

Before proceeding with the installation, you must make sure that:

- The weight and dimensions of the gate are within the specified operating limits.
- The gate is in good mechanical condition and correctly balanced and it opens and closes properly, also the structure of it is suitable for automation.
- There is no danger of gate derailment.
- There will not be flood in the area where the motor is mounted. If necessary, mount the motor raised from the ground.
- After installation, the motor is safe and easy to be released.
- The motor cannot be used with a driven part incorporating a wicket door (unless the drive cannot be operated with the wicket door open).
- Entrapment between the driven part and the surrounding fixed parts due to the opening movement of the driven part is avoided.
- The fixed control is to be located within direct sight of the driven part but away from moving parts. Unless it is key operated, it is to be installed at a minimum height of 1.5 m and not accessible to the public.
- After installation, the mechanism is properly adjusted and that the protection system and any manual release can function correctly.
- Permanently fix the label concerning the manual release adjacent to its actuating member.

4-9. Transmitter mode setting (Switch 1 on SW1)

ON = More than one button in a transmitter can be memorized

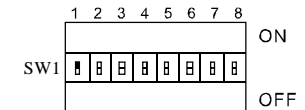

Note: 1.By this setting, the button is for full closing/opening only.
2.By this setting, pedestrain access function is invaild.

OFF = Only one button in a transmitter for full closing/opening and/or one button for pedestrain access can be memorized.

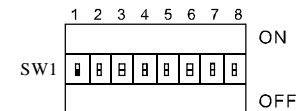



4-10. Memorizing a new transmitter

1) Full closing/opening button coding:

Press  for 2S and release, the DL5 LED will be on, press the desired button twice to control the sliding gate opener, the D15 LED will be off, which indicates the button is memorized.

2) Pedestrian access button coding:

Press  for 2S and release, the DL5 LED will be on, press  again, the D15 LED will be flashing, press the desired button twice to control the sliding gate opener for pedestrian access, the DL5 LED will be off, which indicates the button is memorized.

(**Note:** If you want to exit the coding during the flashing of DL5 LED, press  again to make the DL5 LED turn off.)

Note: 1. Max 16 transmitters can be memorized.
2. Transimtter working mode: OPEN-STOP-CLOSE

4-11. Deleting all transmitters

Press  button for about 8S until the  LED turns off.

(**Note:** If the procedure is performed correctly, pressing any control buttons of any transmitters can not make the unit work.)

4-5. Travel limit switch NC/NO setting (Switch 4 on SW1)

ON = Travel limit switch normal close

OFF = Travel limit switch normal open

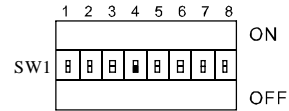

Note: The default setting is OFF, do not change it if not necessary, otherwise the unit can not work.

4-6. Closing direction setting (Switch 5 on SW1)

WARNING: If the closing direction is incorrect, it may lead to serious injury or property damage.

Put the switch to ON / OFF to select the correct closing direction.

ON= Closing direction at right

OFF= Closing direction at left

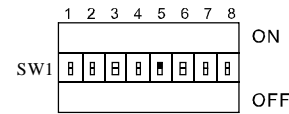

Note: If the setting is correct, during opening, the gate will stop when it meets any obstacles and during closing, the gate will reverse to open when it meets any obstacles.

4-7. Automatic closing time setting (Switch 6, 7, 8 on SW1)

The time can be added up combinatorially and set from 0-70S

6=10S

7=20S

8=40S

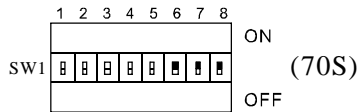

Put all the switches to ON, the automatic closing time is 70S, put all the switches to OFF, the gate will not close automatically.

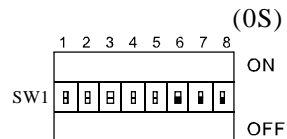

4-8. Force setting

WARNING: If the force is set too weak, the gate can not work in normal, if the force is set too strong, it may lead to serious injury or property damage.

Turn it clockwise, the force will become stronger.

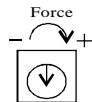

Turn it anticlockwise, the force will become weaker.

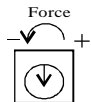

3-1 Description of the Automation

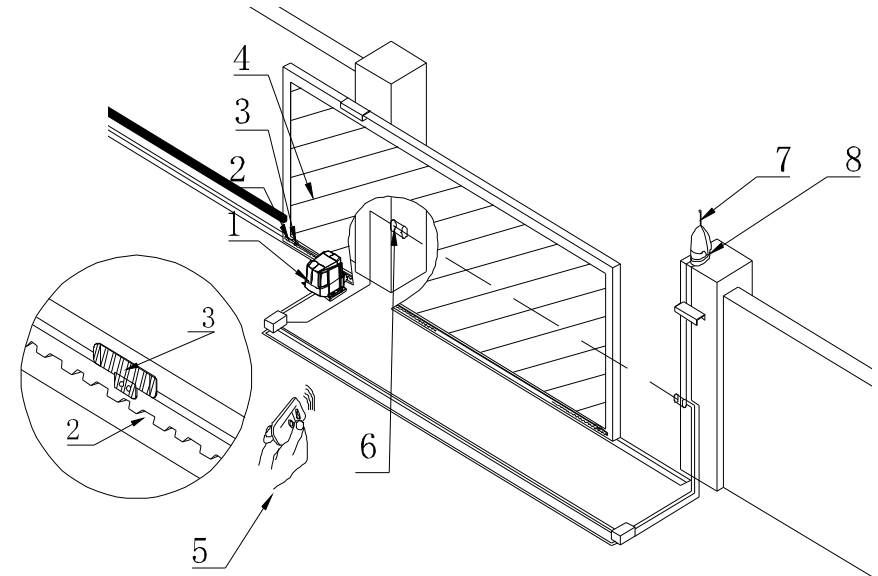

Fig. 1

- | | |
|-------------------------|--------------------|
| 1. Motor | 5. Transmitter |
| 2. Rack | 6. Infrared sensor |
| 3. Limit switch bracket | 7. Antenna |
| 4. Sliding gate | 8. Flashing light |

Wire specification:

Power input: 3x1.5 mm²

Flashing light input: 2x1.5 mm²

Photocell input: 4x0.5 mm²

3-2 Essential tools

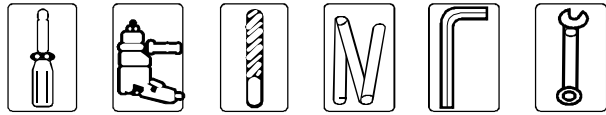

Fig. 2

3-3 Rack installation

(**Note:** Please check whether the sliding gate can be moved smoothly before installation; release the clutch with the release key.)

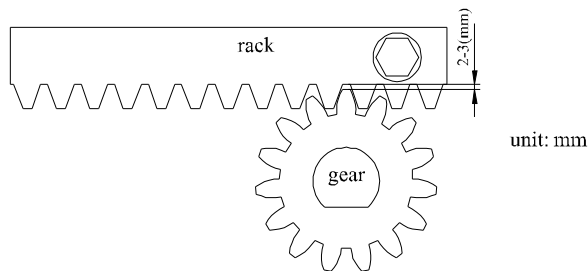

Fig. 3

Warning: There must be a clearance of 2-3 mm between the rack and gear as Fig 3, in case the motor function and manual operation may be effected.

Note: Please install the rack as show in Fig. 3. If the rack is installed under the gear, please exchange the connection of SW1 & SW2.

Note: 1. During the travel limit learning, the PCB will save the opening /closing time whichever is longer as the travel limit time.

(eg. If the opening learning time is 15S, the closing learning time is 20S, the PCB will save 20S as the travel limit time.)

2. If there is no limit switch bracket installed to stop the gate, the gate will run for 2Mins and stop. The PCB will exit the programm automatically.
3. During the learning, the DL6 LED will keep flashing until the learning is finished.

4-3. Pedestrian access setting: (Switch 2 on SW1)

When the gate is closed completely, press the pedestrian access button on the transmitter (see P14 / 4-10), the gate will open a 1.5 meter pedestrian access and stop. But there is no pedestrian access for closing motion.

ON= With pedestrian access

OFF= No pedestrian access

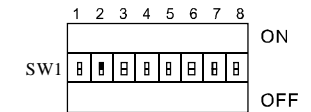

4-4. Soft stop setting (Switch 3 on SW1)

The gate stops softly before the opening/closing motion is almost finished.

ON = With soft stop

OFF = No soft stop

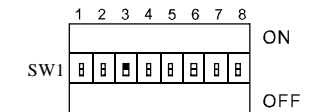

Note: Soft stop length adjustment. (LV button)

Turn it clockwise, the soft stop length will become longer.

Turn it anticlockwise, the soft stop length will become shorter.

4、Programming

4-1 Control board wiring diagram

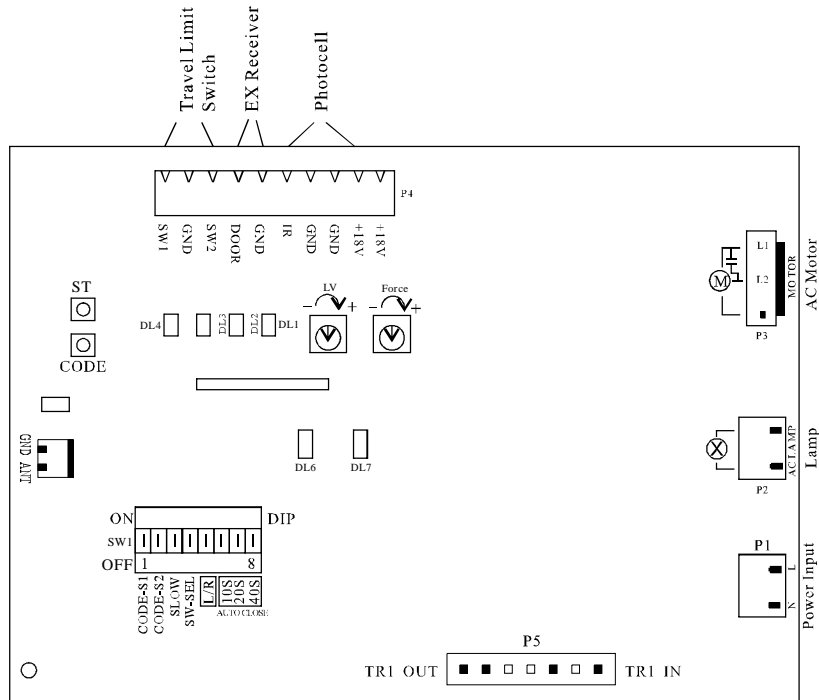



Fig. 10

4-2. Travel limit learning

Note: If the travel limit learning is not applied, the sliding gate opener can not work normally.

- a) Start the learning when the gate is closed fully. Press button  for 5S, the DL6 LED will flash.

(Note: The PCB will exit the programm automatically after 30S if there is no further operation, during the time DL6 LED keeps flashing.)

- b) Press button  again, the gate will open and stop for 1S when the switch spring reaches the open limit switch bracket. Then the gate will reverse to close automatically until the switch spring reaches the close limit switch bracket. The travel limit learning is finished, and the PCB will save the learning time.

3-4 Base plate installation

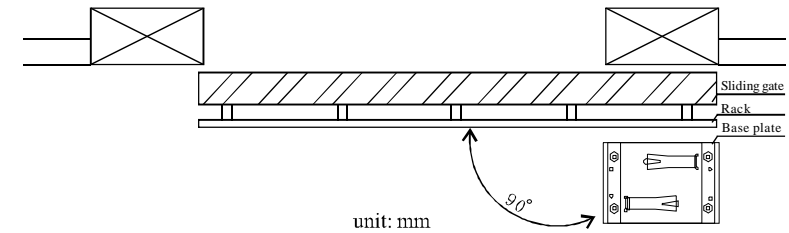

Fig. 4

3-5 Motor fixing

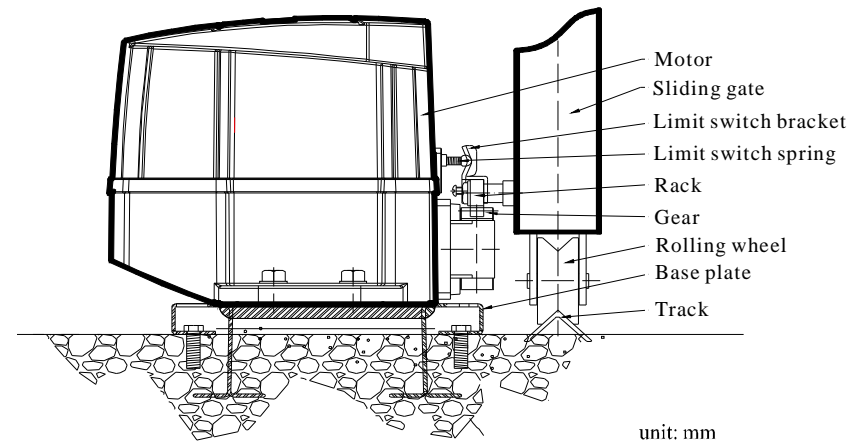

Fig. 5

3-6 Limit switch bracket installation

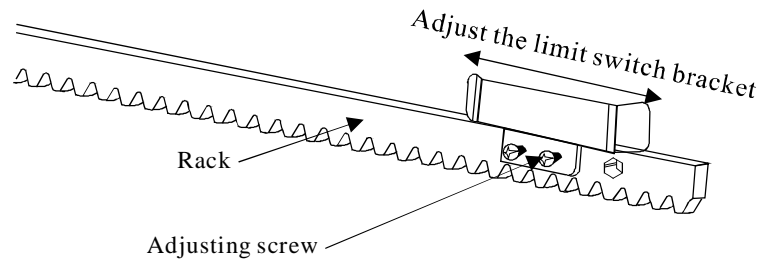

Fig. 6

3-7 Photocell installation

a. Wiring diagram

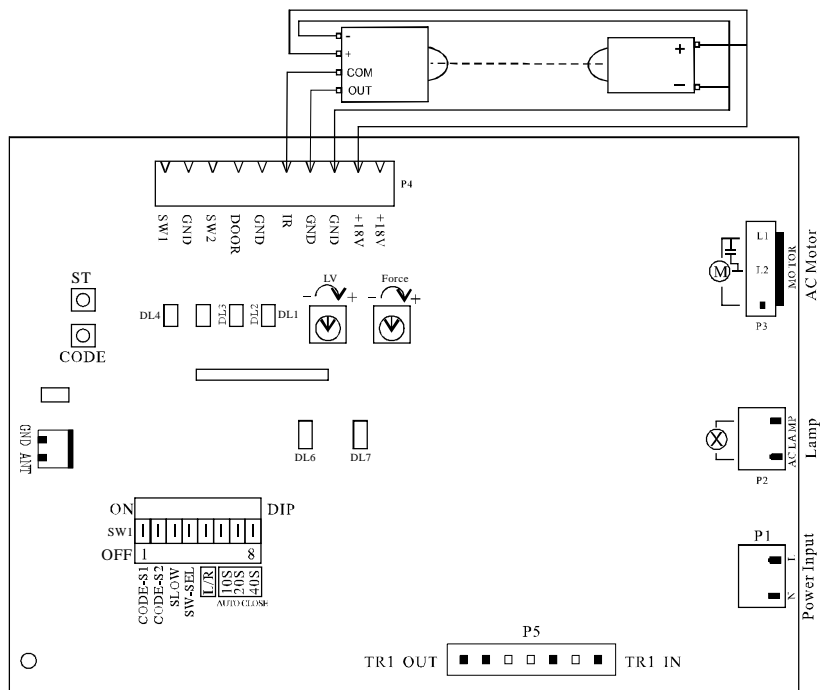

Fig. 7

b. Photocell specification

Detecting way	Max. distance	Volt	Current	Output way
Emitting and receiving	12m	12-24V	150 mA	NO / NC

Note 1: The photocells should be installed at a height of 40-60cm from the ground, and the distance to the gate edge should not larger than 15cm. The emitter should point towards the receiver, with a max. tolerance of 5°.

Note 2: When the photocell sensors are wired correctly, the DL1 LED will be on, the DL1 LED will be off when the photocell beam is interrupted.

WARNING: It is recommended that the sliding gate opener must be installed with photocell, which can reduce the risks of body injury or property damage.

The photocell function is closed when set in the factory and the terminals IR and IR GND has connected with a cable. If you want to connect the photocell please take out the cable and connect according to the photocell connection on P9.

3-3 Emergency release

In the case of power failure: Insert the release key and turn it anticlockwise to disengage the clutch, this will allow the gate to be opened or closed manually(Fig.8).

When power recovers: Insert the release key and turn it clockwise to engage the clutch(Fig.9).

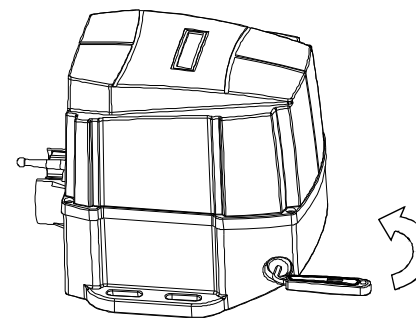

Fig. 8

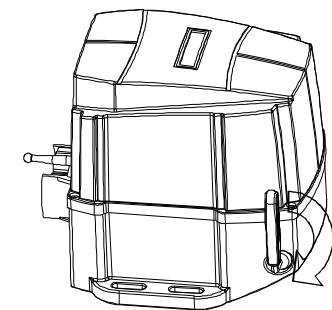

Fig. 9