

All rights reserved

# Swing Gate Opener

## ASSEMBLING AND OPERATING MANUAL

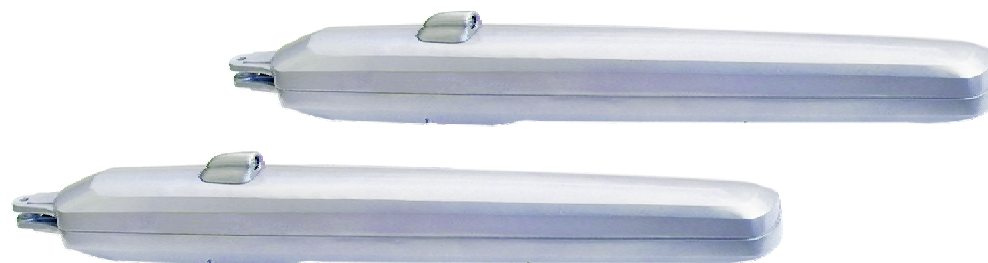

***F-600***

**PLEASE READ THE MANUAL CAREFULLY BEFORE INSTALLATION AND OPERATION**

## Contents

1.Inventory .....	3
2.Installation Tools .....	4
3.Layout of Gate Opener and Wiring for Control Unit	4-5
4.Standard Installation .....	5-9
5.Clutch Release .....	10
6.Installation for Control Box .....	10-12
7.Opening and Closing Travel Limit Setting .....	13
8.Transmitter Programming .....	13-14
9.Function Introduction .....	14-16
10.Technical Specification .....	16
11.Trouble Shooting .....	17
12.Recycling and Manipulation .....	18

## 12. Recycling and Manipulation

There are different kinds of material in a swing gate opener. Some can be recyclable, such as aluminium, iron, plastic, wires etc., but some of them can't.

**Warning :** Lead-acid backup battery and some electronic material are harmful substances. In order not to get the environment polluted, they should be recycled or discarded according to requirements of the local law regulation.

1. Completely cut off the power supply.
2. Disassemble all the equipments and accessories.
3. Take out the backup battery from the control box and the battery from transmitters.
4. Take out the PCB.
5. Recyclable materials should be handled by the local qualified company.
6. Backup battery, battery from transmitter and control board, etc. with harmful substances should be handled by the local qualified company so that they won't cause any pollution to the environment.

## 11. Trouble Shooting

Troubles	Causes	Solutions
The gearmotor doesn't work.	<ol style="list-style-type: none"> <li>1.The plug is not securely connected.</li> <li>2.The fuse on the pcb is blown.</li> </ol>	<ol style="list-style-type: none"> <li>1.Have the power supply connected securely by a qualified technician.</li> <li>2.Replace with a new fuse of the same type.</li> </ol>
The gearmotor doesn't work when operating the transmitter.	<ol style="list-style-type: none"> <li>1.The transmitter has not been memorized.</li> <li>2.The battery of the transmitter has not enough power.</li> <li>3.The clutch is dis-engaged.</li> </ol>	<ol style="list-style-type: none"> <li>1. Memorize the transmitter referring to 8 on P13.</li> <li>2.Replace with a new battery of the same type .</li> <li>3.Engage the clutch with the release key .</li> </ol>
The transmitter distance is short .	The battery of the transmitter has not enough power after long time use.	Replace with a new battery of the same type .
The moving speed of the gate leaf is slow .	<ol style="list-style-type: none"> <li>1.The installation of the gate is not proper, so the moving become not smooth .</li> <li>2.The moving speed of the gearmotor is not adjusted properly.</li> </ol>	<ol style="list-style-type: none"> <li>1.Release the gearmotor and move the gate leaf by hand to see if it can move smoothly.</li> <li>2.Set the moving speed referring to (8) on P15 .</li> </ol>
The gate leaf can not open or close completely or it does not move .	<ol style="list-style-type: none"> <li>1.The photocell sensor is shielded.</li> <li>2.The operating time of the gearmotor is not adjusted properly.</li> </ol>	<ol style="list-style-type: none"> <li>1.Check and make sure the photocell sensor is not shielded.</li> <li>2.Set the operating time referring to (9) on P16.</li> </ol>
The gate leaf can not close automatically .	<ol style="list-style-type: none"> <li>1. The auto closing function is set OFF .</li> <li>2.The wire connection of the unit is not correct .</li> </ol>	<ol style="list-style-type: none"> <li>1. Set the auto closing time referring to (5) on P15.</li> <li>2. Connect the wire referring to the wiring diagram on P12 .</li> </ol>

## IMPORTANT SAFETY INSTRUCTIONS

**WARNING: It is important for the safety of persons to follow these instructions. Save these instructions.**

- Do not allow children to play with fixed controls. Keep transmitters away from children .
- Activation of the manual release may cause uncontrolled movement of the driven part due to mechanical failures or an out - of - balance condition .
- When operating a biased-off switch, make sure that other persons are kept away .
- When closing a gate that has been opened by a fire-sensing system, make sure that other persons are kept away .
- Frequently examine the installation for imbalance and signs of wear or damage of cables, springs and mounting. Do not use if repair or adjustment is necessary .
- The supply must be disconnected when cleaning or other maintenance is being carried out .
- This appliance is not intended for using by persons (including children) with reduced physical, sensory or mental capabilities, or lack of experience and knowledge, unless they have been given supervision or instruction concerning use of the appliance by a person responsible for their safety .

Children should be supervised to ensure that they do not play with the appliance .















- The means for disconnection must be incorporated in the fixed wiring in accordance with the wiring rules. An ON/OFF switch with a minimum distance of 3 mm between contacts in all poles must also be connected to the power supply .
- If the supply cord is damaged, it must be replaced by the manufacturer, its service agent or similarly qualified persons in order to avoid a hazard .
- Only power cord with H05RN-F2×0.75mm<sup>2</sup> type can be used .
- The replacement of battery should be carried out by professional people .

Correct disposal of this product:

This marking indicates that this product should not be disposed with other household wastes throughout the EU. To prevent possible harm to the environment or human health from uncontrolled waste disposal, recycle it responsibly to promote the sustainable reuse of material resources. To return your used device, please use the return and collection systems or contact the retailer where the product was purchased. They can take this product for environmental safe recycling.



## 1.Inventory

Picture	Name	Quantity
	Gearmotor	2
	Instruction manual	1
	Transmitter	2
	Rear mounting brackets	2
	Front mounting brackets	2
	Flashing light	1
	Photocell	1
	Control Box	1
	Release key	3
	Cotter pin	2
	Clevis pin	2
	M8x60 screws	8
	Wall console	Optional
	Keypad	Optional
	Keyswitch	Optional

### (9) Operating time setting:

Turn button TIMER clockwise, the operating time will be longer;  
Turn button TIMER anticlockwise, the operating time will be shorter;  
The time can be set from Max.63S to Min. 30S

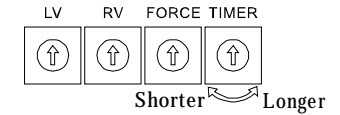

### (10) Electric lock(optional)

LOCK and – are connectors for electric lock, F-600(12V/DC-A) and F-600(12V/DC-B) match with 12V/500mA electric lock; F-600(24V/DC-A) matches with 24V/500 mA electric lock. When the electric lock is connected, it will open before the gate leaf opens.

### (11) The wired control connectors( Key switch)

DOOR1, - and DOOR 2 are the connectors for wired control(for normal open only).  
When DOOR1 and – are connected, only MOT1 gearmotor will work and DL5 LED will turn on;  
When DOOR2 and – are connected, both gearmotors will work and DL4 LED will turn on.

### (12) The photocell connectors:

The connectors for photocell are normal closed. If the control unit is installed without photocell, connect terminals IR1, IR2 and - with a short cable, otherwise the unit will not be operated(these 3 connectors have been connected in factory). If only IR1 is used, please connect IR2 and terminals with a short cable. When the beam of photocell IR1 is interrupted by obstacles, the gate leaf will stop and reverse. DL2 LED on the main panel will turn off. If only IR2 is used, connect IR1 and - with a short cable. When the beam of infrared IR2 is interrupted by obstacles, the gate leaf will stop. DL3 LED on the main panel will turn off.

## 10.Technical Specification:

Model	F-600
Working Power (Vac)	220~240Vac @ 50/60Hz
Motor Voltage (Vdc)	24
Input Power (W)	100
Ambient Temperature Range (°C)	-25 ~ +50
Max. Weight for Single Gate Leaf (Kg)	350
Max. Width for Single Gate Leaf (m)	1.8 2.5(with electric lock)
Max. Open Angle (°)	120
Protection Level (IP)	24
Max. Travel Distance (mm)	320
Working Period	Max.50 continuous working cycles for frequent operation
Weight for per Gearmotor (KG)	6

- (2) **Opening /closing delay setting**  
 (Default: MOT2 gearmotor will open first.)  
 4 ON= MOT2 gearmotor will open first  
 4 OFF=MOT1 gearmotor will open first

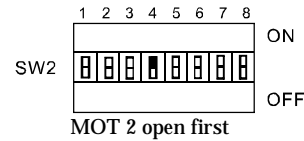

- (3) **Single gate leaf operation setting**  
 5 ON= Only MOT1 gearmotor is available  
 5 OFF=Both MOT1 and MOT2 gearmotors are available

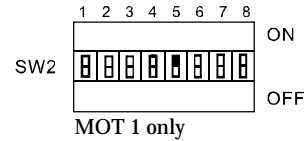

- (4) **Operation mode setting**  
 6 ON= The operation mode is :  
 OPEN-CLOSE-OPEN  
 6 OFF= The operation mode is:  
 OPEN-STOP-CLOSE-STOP-OPEN

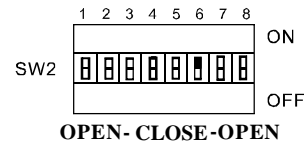

- (5) **Auto closing setting:**  
 7 ON= The unit can not receive any operating command before automatically closing.  
 7 OFF= The unit can receive operating commands before automatically closing.

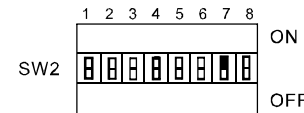

**Auto closing time setting:**  
 (This function is set OFF in factory.)  
 The time can be added up combinatorially and set from 0 -210 seconds.  
 1 = 30S  
 2 = 60S  
 3 = 120S  
 Put all the switches to ON position, the auto closing time is 210 seconds. Put all the switches to OFF position, the gate leaf will not close automatically.

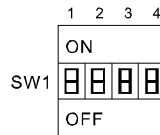

- (6) **Force adjustment:**  
 Turn button FORCE clockwise, the driving force will become stronger. Turn it anticlockwise, the driving force will become weaker.

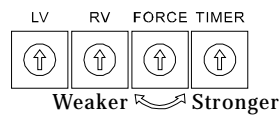

- (7) **Soft start and stop speed setting:**  
 Turn button LV clockwise, the speed will be faster.  
 Turn it anticlockwise, the speed will be slower.

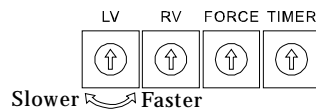

- (8) **Moving speed setting:**  
 Turn button RV clockwise, the speed will be faster. Turn it anticlockwise, the speed will be slower.

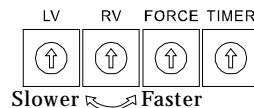

## 2.Installation Tools

(Make sure you have all the following tools and they are in good conditions and serviceable according to the safety standards)

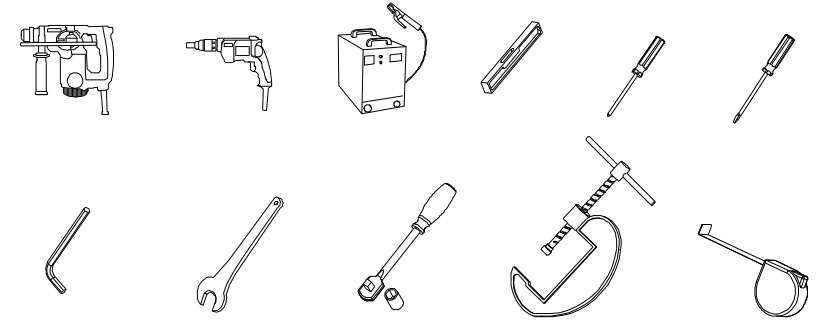

## 3. Layout of Gate Opener and Wiring for Control Unit (Fig.1)

(The gearmotor has been wired properly inside, cables of 800 mm are supplied with the gearmotor)

Fig. 1

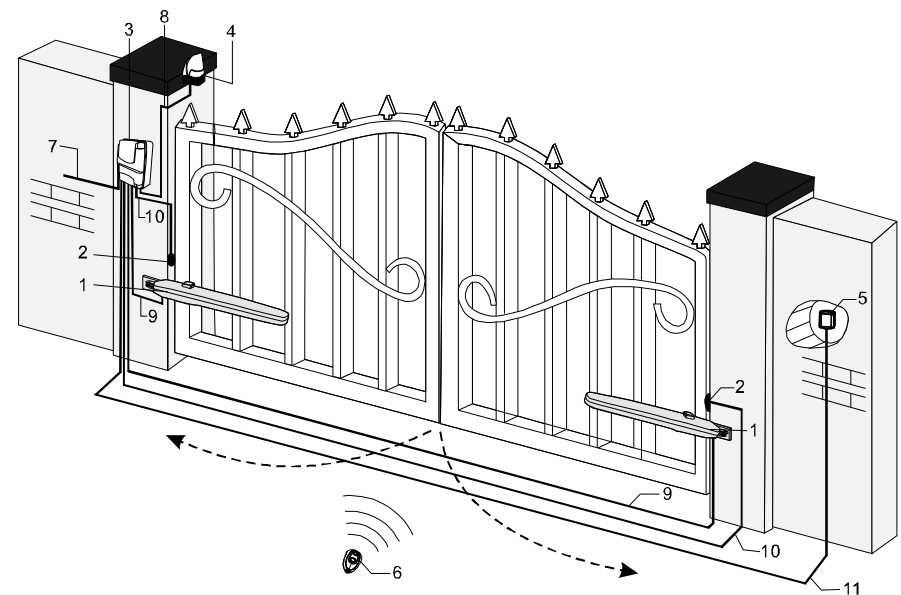

- |   |                        |
|---|------------------------|
| 1. F-600 Gate Opener  | 2. FA30 Photocell      |
| 3. FA70 Control Box   | 4. FA40 Flashing Light |
| 5. Key Switch or Keypad (optional)  | 6. FR32 Transmitter    |
| 7. Power Cable : $3 \times 1.5\text{mm}^2$                                      |                        |
| 8. Cable for Flashing Light : $2 \times 1.0\text{mm}^2$                         |                        |
| 9. Cables for MOT1 & MOT2   |                        |
| 10. Cable for Photocell: $4 \times 0.5\text{mm}^2$ or $2 \times 0.5\text{mm}^2$ |                        |
| 11. Cable for Key Switch: $2 \times 1.0\text{mm}^2$                             |                        |

**WARNING:** Make sure the cables you used meet with the above installation types and the wiring system is in a safety ground surrounding.



## 4. Standard Installation

### For installation instructions:

**WARNING: Important safety instructions. Follow all instructions since incorrect installation can lead to severe injury.**

- Before installation, the installer should check the type, size and mass of the driven part, and locations where the drive can be installed.
- Before installing the drive, check whether the driven part is in good mechanical condition, correctly balanced and open or close properly.
- The drive cannot be used with a driven part incorporating a wicket door.
- Ensure that entrapment between the driven part and the surrounding fixed parts due to the opening movement of the driven part is avoided.
- Whether the actuating member of a biased-off switch is to be located within direct sight of the driven part but away from moving parts. Unless it is key operated, it is to be installed at a minimum height of 1.5 m and not accessible to the public.
- After installation, ensure that the mechanism is properly adjusted and that the protection system and any manual release function correctly.
- Permanently fix the label concerning the manual release adjacent to its actuating member.
- Make sure that the mounting surfaces of the photocell sensors are flat and they can enable proper alignment between TX and RX.
- Make sure that there will be enough space for the gates to open and close.

### b. Programming transmitter button for single leaf :

**CODE**  
Press  and hold for 2S, the code LED DL6 is on, press  again, the code LED DL6 is flashing, press button 2 of the transmitter twice, the code LED DL6 is off, button 2 can operate one of the leaves.

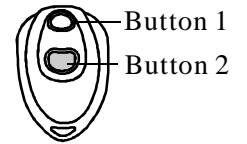

**Note:** 1. When the code LED DL6 is flashing, if the user does not need to

programme transmitter button for single leaf, press **CODE**  button to exit the programming.

2. The control unit can memorize Max. 25 pcs transmitters.
3. If button 1 is for both leaves, button 2 is for single leaf, it is invalid to code button 1 for single leaf.
4. If button 1 is for both leaves, button 2 is for single leaf, now the user programmes button 2 for both leaves, then button 1 will be invalid at the same time.

### 2. Deleting all transmitters:

**CODE**  
Press  and hold for 10S to delete all transmitters.

(**Note:** If the procedure is performed correctly, press the buttons of any transmitters can not operate the unit.)

## 9. Function Introduction

### (1) Opening/closing delay time setting:

(The delay time is set at 2 seconds in factory)

The time can be added up combinatorially and set from 1-3 seconds.

1 ON: 1 second, 2 ON: 2 seconds,

1 ON } 3 seconds, 1 OFF } 1 second  
2 ON } 2 OFF }

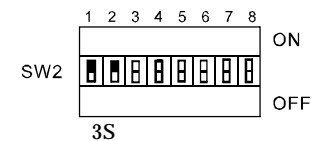

If without any opening/closing delay setting, the default delay time is 1S.

**Note: Switch 3 on SW2 is for reservation.**

## 7. Opening and Closing Travel Limit Setting

(1) Release the clutches of both gearmotors with a release key, open both gate leaves completely, then engage the clutches.

(2) Put DIP switch SW2 No.8 to ON position.

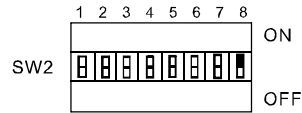

(3) Press button  **ST** on the main board, both gate leaves will move in closing direction and stop until they completely close.

(4) Press button  **ST** again, both gate leaves will move in opening direction and stop until they completely open.

(5) After the recognition, put DIP switch SW2 No.8 to OFF position.

## 8. Transmitter programming

1. Memorizing a new transmitter

Put DIP switch 4 on SW1 to ON:

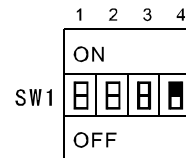

a. Programming transmitter button for both leaves:

**CODE**

Press  and hold for 2S, the code LED DL6 is on, press button 1 of the transmitter twice, the code LED DL6 is off, button 1 can operate both leaves.

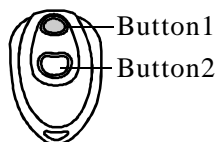

(1) Measurement for gearmotor (Fig.2):

Fig.2: (unit:mm)

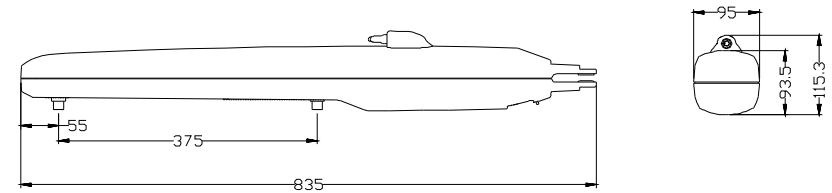

(2) Installation for rear brackets (Fig.3):

- Measure the Value C.
- Value D will depend on the position where the Rear Brackets will be mounted.
- Value A is the total length for both C and D.
- Please refer to Table 1 on page 7, Value B will depend on Value A and the Maximum Opening Angle of the gate leaf.
- The acting force of the gate opener will be more excellent to the gate when Value B is close or equal to Value A.

Fig.3

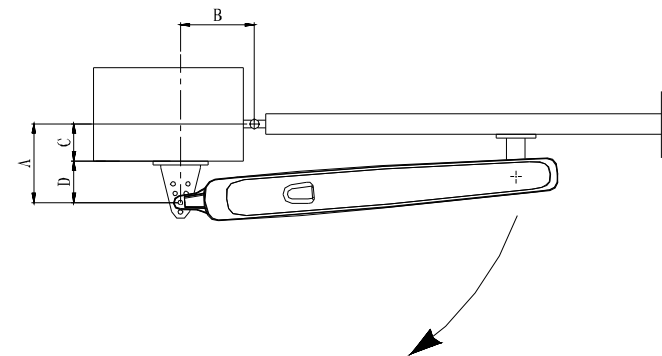
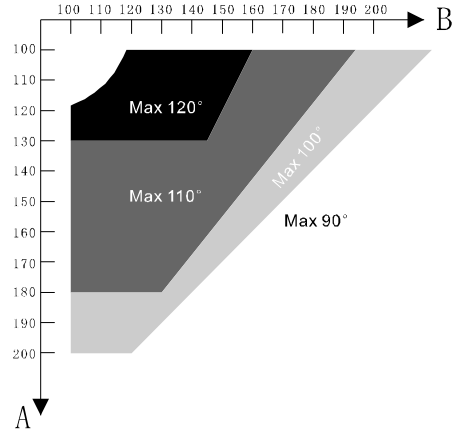
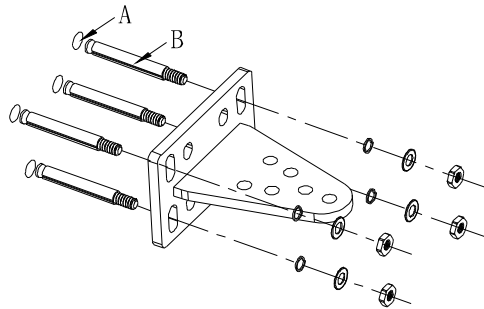

Table 1.



- (3) Refer to Table 1 and choose the sizes of A and B in order to confirm the position where the rear brackets will be mounted. Use the bracket itself as a reference ( Fig.4 ), mark the drill points for the rear bracket. Drill 4 holes (A) in the mounting surface, and fix the bracket with the appendant setscrews(B), then fix the bracket with screw nuts.

Fig.4



- (4) The slots on the bracket allow small differences in alignment to be corrected. Fix the bracket with the nuts when the bracket is perfectly level. ( Fig.5 )

Fig. 5

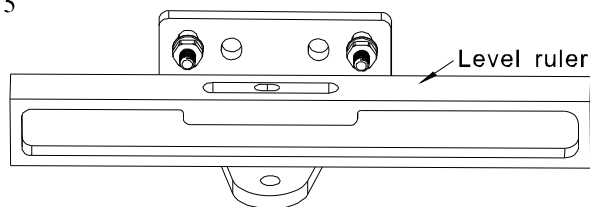

4. Wiring diagram (Fig.16):

Fig. 16

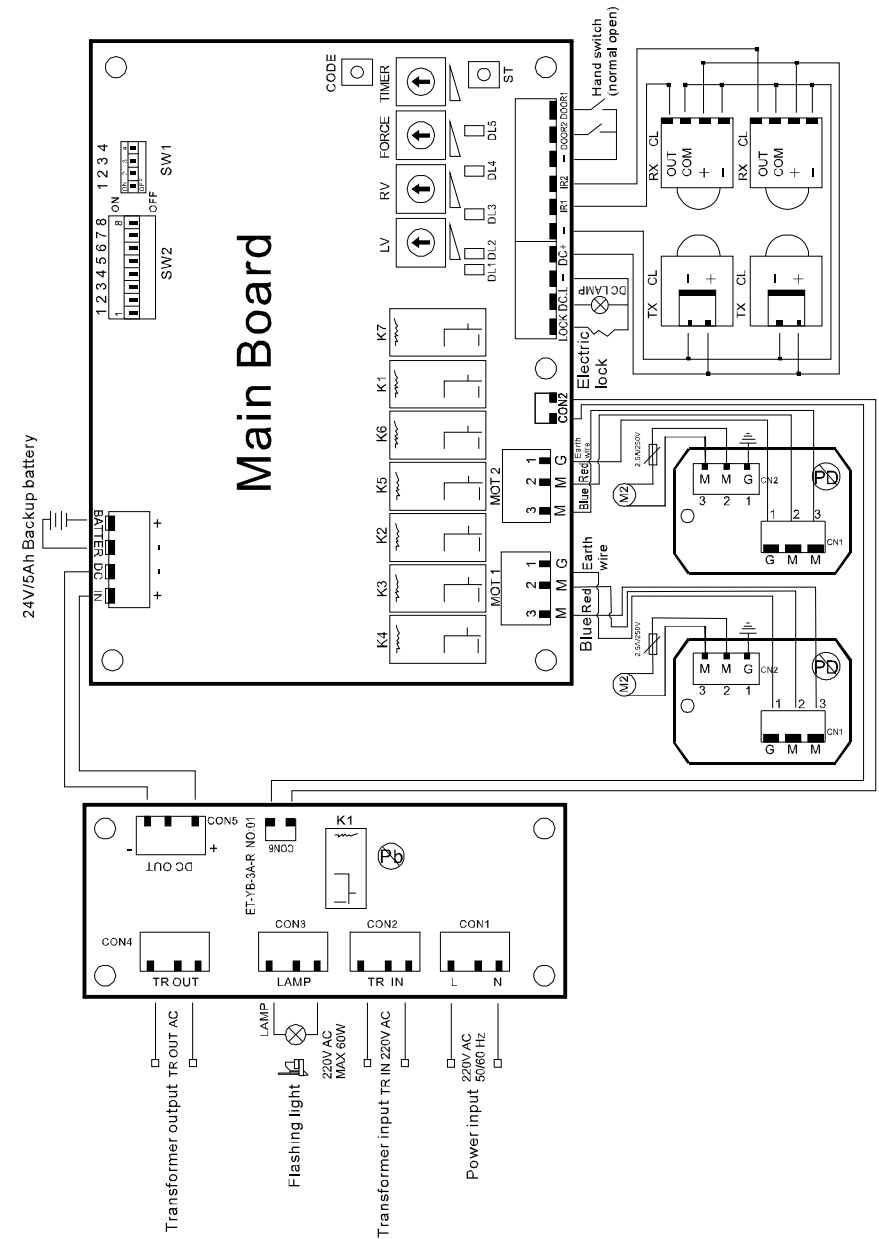



2. Refer to Fig.1, install the control box at height of 1.7 meters above the ground. (Fig.14)

Fig. 14

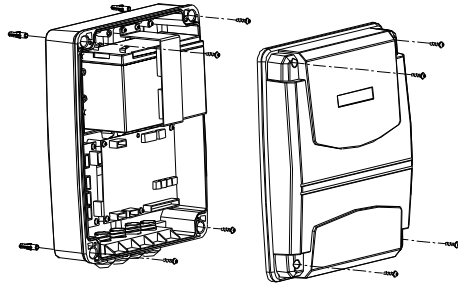

3. The structure of control box (Fig.15):

Fig. 15

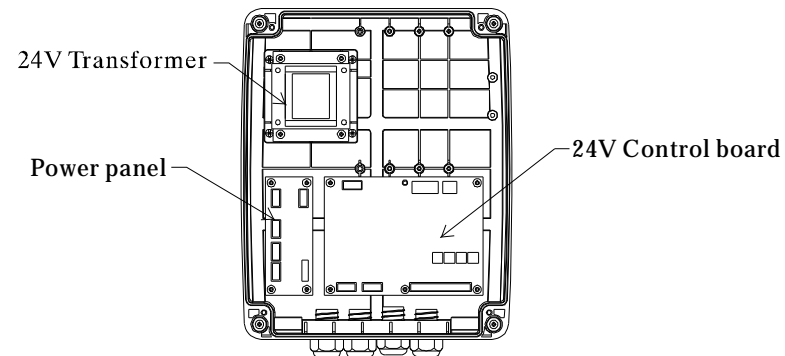

(5) Refer to the following figure, place the front bracket at a distance of 730 mm from the rear bracket and 38mm lower than the rear bracket. ( Fig.6 )

Fig. 6: (unit: mm)

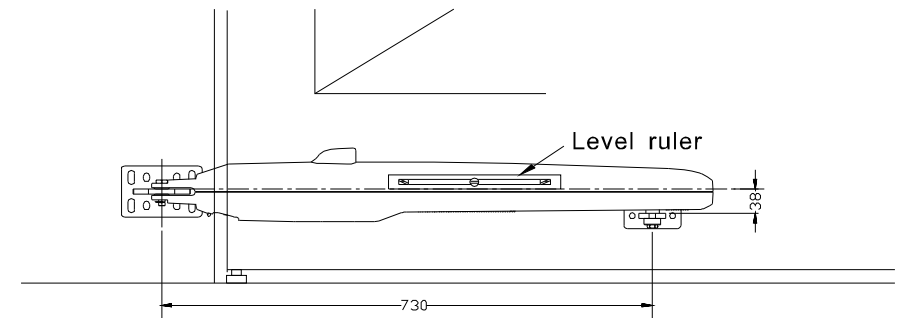

(6) Fix the front bracket to the leaf with a clamp provisionally ( Fig.7). Lift up the gearmotor and fit the fork into the hole in the front bracket, keep the gearmotor lifted and pull it to open the gate until the hole in the bracket matches the hole in the gearmotor. Fix the gearmotor to the rear bracket with the cotter pin and then insert the clevis pin into the cotter pin. ( Fig.8 )

Fig. 7

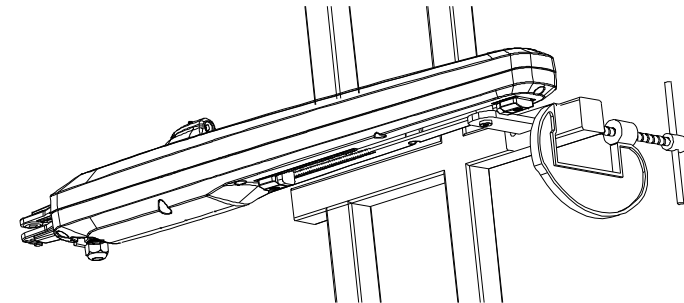
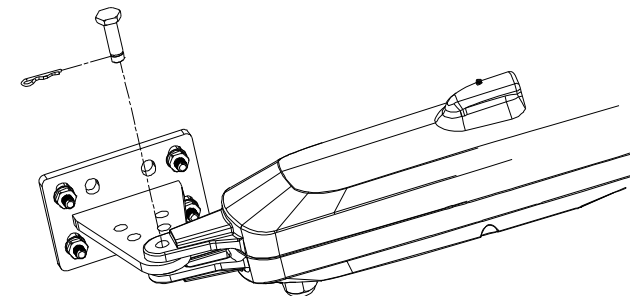
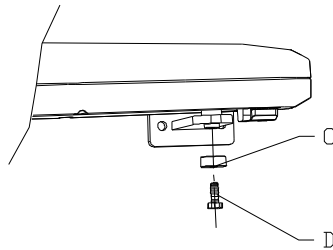

Fig. 8



- (7) Fix the gearmotor to the front bracket and anchor it with the appendant screws (D) and washers (C) with the gearmotor, fully tighten the screw. (Fig.9)

Fig. 9



- (8) Release the gearmotor clutch with the release key (See P10. "Clutch Release" paragraph below ).
- (9) Move the gate by hand and check whether the mechanism of the gate works well.
- (10) Release the locating screws E and F, and close the gate to a suitable position, then adjust and contact the locating screw E and locating stopper G. Open the gate to a suitable position, then adjust and contact the locating screw F and locating G, mount lock the opening locating screw F. (Fig.10)

Fig. 10

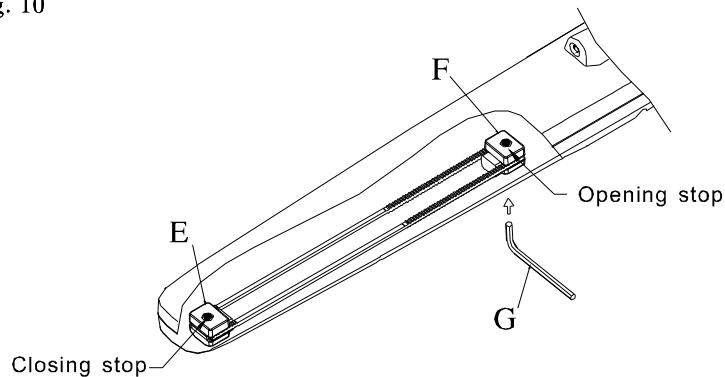

- (11) Fix the front bracket permanently. ( e.g. welding or fix with screws.)
- (12) Engage the gearmotor with the release key (See P10. "Clutch Release" paragraph below )

## 5. Clutch Release

Fig. 11

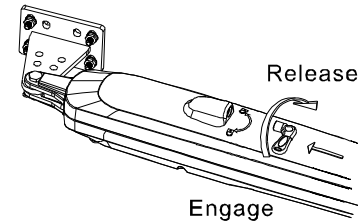

The clutch release for the left gearmotor

Fig. 12

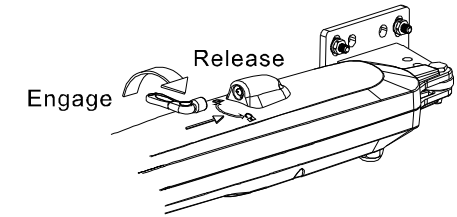

The clutch release for the right gearmotor

(Fig.11 & Fig.12) Release the clutch: Insert the release key and turn it clockwise for  $180^\circ$ . Engage the clutch: Insert the release key and turn it  $180^\circ$  in an opposite direction.

## 6. Installation for Control Box

### 1. Size of control box (Fig.13):

Fig. 13

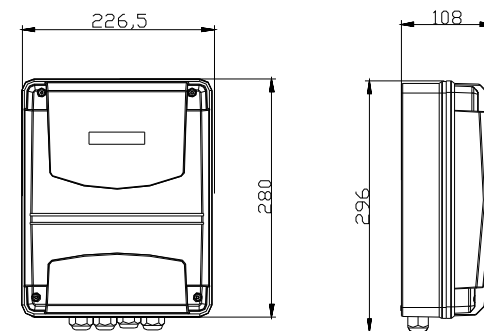

(unit: mm)